

## Valvola a sfera K flangia - garolla

K ball valve flange - garolla end

K Kugelventil Flansch - Garolla Anschluß

Vanne à boule K bride - garolla

Válvula de bola K brida - garolla

AISI 304 - 316

art. 78

DN	A	B	C	D	E	F	G	H	L
40	110	65	110	40	95	18	150	4	180
50	110	76	125	49.5	100.5	18	165	4	180
60	124	87	145	57.5	107.25	18	185	4	205
70	124	97	160	69	125.5	18	200	4	266
80	162	108	160	79	136.5	18	200	4	266
100R	216	129	180	89	144.5	18	220	8	266

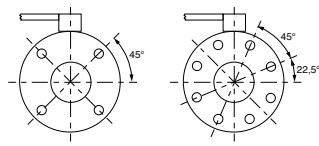

Posizione dei fori flangia rispetto alla valvola  
 Position of the flange holes welded to the valve

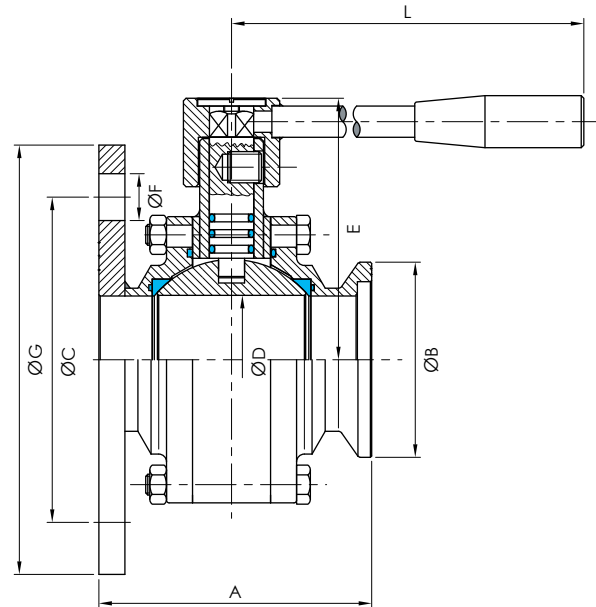

## Valvola a sfera K attacchi garolla

K ball valve garolla ends

K Kugelventil Garolla - AnschluÙe

Vanne à boule K DIN femelle - garolla

Válvula de bola K tuerca DIN - garolla

AISI 304 - 316

art. 79A

DN	A	B	D	E	F
40	102	65	40	95	180
50	102	76	49.5	100.5	180
60	114	87	57.5	107.25	205
70	124	97	69	125.5	266
80	152	108	79	136.5	266
100R	154	129	89	144.5	266

